

6 – Channel LED Driver

FEATURES

- Wide input range from 2.7V to 24V
- Integrated 2.7A/40V boost converter FET
- Built-in loop compensation and soft-start
- Six programmable current sinks
 - Current up to 30mA per channel
 - PWM dimming from 100Hz to 30kHz
 - Ultra low dimming cycle 0.005% @ 100Hz dimming frequency
 - 2.5% current matching
 - 3% current accuracy
- Protection:
 - LED string open/short detection
 - Overvoltage protection
 - Overcurrent protection
 - Overtemperature protection
- Thin 3x3 mm 16-lead WQFN package
- Rohs compliant and 100% Lead(Pb)-Free/Green

QFN-16PIN CONFIGURATION

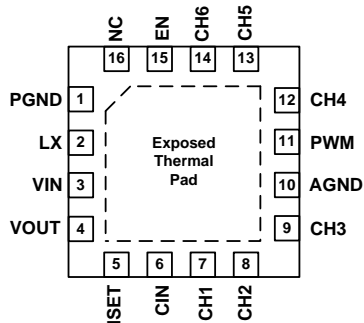

APPLICATIONS

- Notebook/Ultrabook/Tablet PC Display Backlight
- Car Navigator/Entertainment Display Backlight
- Flash light or utility light

DESCRIPTION

The ANX6923 is a highly compact white LED driver especially optimized for thin-film transistor (TFT) liquid crystal displays (LCDs) backlight. The chip can drive up to six strings of LEDs and up to ten LEDs in series per string. Wide input voltage range from 2.7V to 24V makes ANX6923 well suited for applications ranging from a one-cell lithium-ion battery tablet PC to a full-size notebook PC.

The ANX6923 offers a built-in high efficiency current mode boost converter. The six integrated current sink regulators provide high precision current regulation and matching for LED currents up to 30mA. The feedback loop senses LED current sink voltages and compensates for the non-uniformity of the LED forward voltage accumulated on the LED strings. To minimize the power loss, the output voltage of the boost converter is automatically adjusted by monitoring the highest forward voltage of the LED strings. An unused LED channel can be disabled by connecting the channel to ground.

The ANX6923 controls LED dimming through the pulse-width-modulation (PWM) method. The LED current is turned on and off in response to the duty cycle and frequency applied at the PWM pin.

The ANX6923 features several protection functions including overcurrent protection (OCP), overtemperature protection (OTP), overvoltage protection (OVP), and LED string open and short detection. Once the device is turned on, the soft-start function raises the output voltage gradually to avoid voltage overshoot and inrush current. If one string opens, the LED open detection circuit detects this fault and excludes this current sink from the regulation loop. All other strings continue to work normally.

ORDERING INFORMATION

Part Number	Package
ANX6923AAQ	WQFN-16L, 3x3